

DBS MANUFACTURING

ENGINEERED FIRSTS | BUILT TO LAST

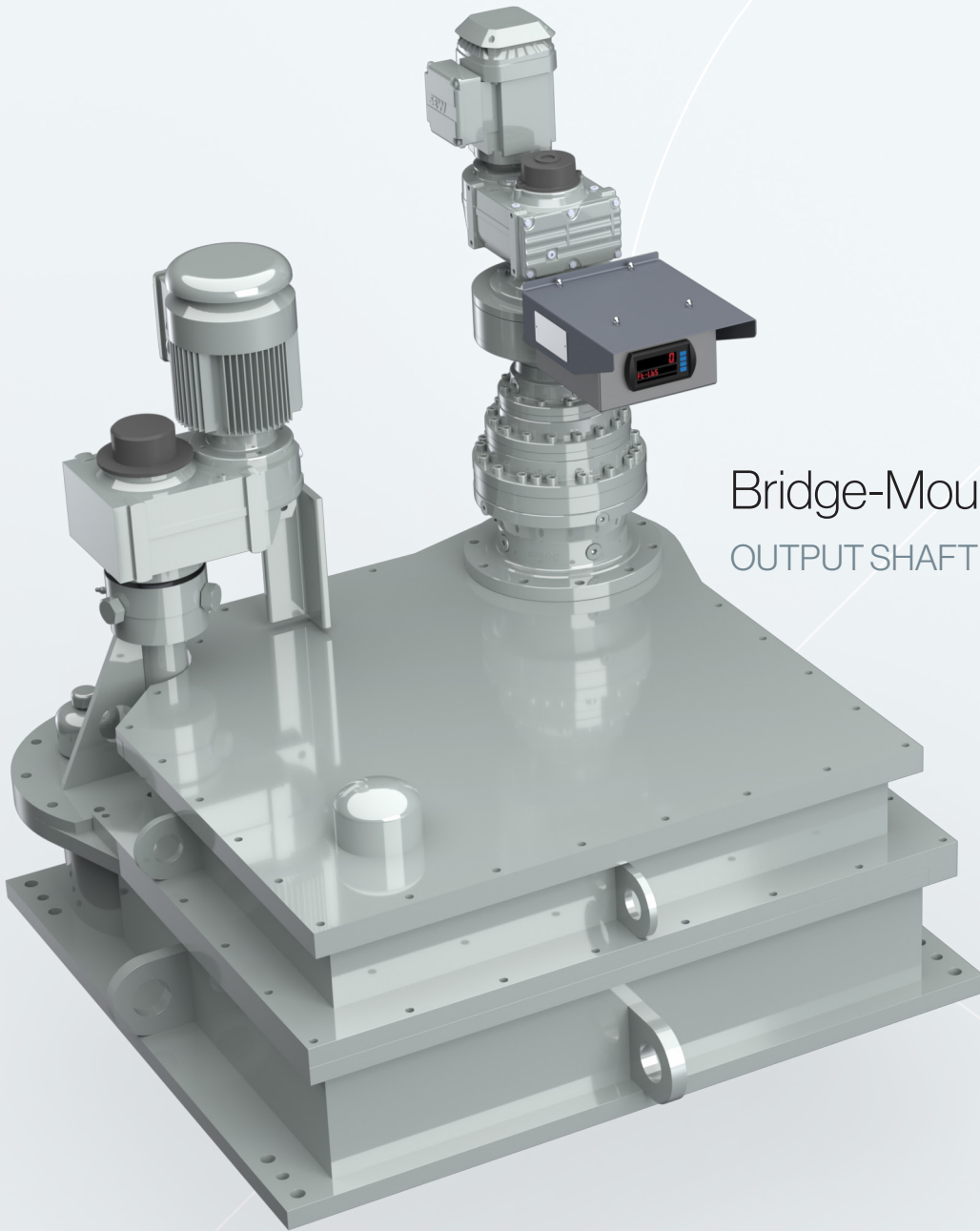

Bridge-Mounted | Dual Concentric
OUTPUT SHAFT DRIVE UNITS

DBS MANUFACTURING, INC.

DBS is a successful, privately held business that designs, manufactures, and provides application engineering for products sold to original equipment manufacturers, end users, and municipal and industrial facilities around the world.

Bridge-Mounted Dual Concentric Output Shaft Drive Units

These drive units offer a robust low-speed, high-torque gear drive with overload protection. Ideal for solids contact and flocculating clarifiers or softeners, they feature a design supported by a bridge that spans the tank and dual central output shafts to drive the rakes.

Designed for tanks ranging from 10 to 100 feet (3 to 30 meters) in diameter, the units include a forged alloy steel main gear and pinion designed for a 20-year lifespan. They also feature a precision, four-point-contact main bearing with a 10-year warranty. The rake drive comes equipped with an accurate torque gauge calibrated to your preferred units while the turbine drive comes standard with variable speed.

For protection, each unit comes with alarm and cutoff switches in addition to mechanical torque limiting with a shear pin or pressure relief valve. The design also eliminates the lower pinion-bearing, a common failure point. It is also designed for minimal maintenance with a permanently lubricated intermediate gearbox and dry well lubrication on the turbine output.

In summary, the dual shaft drive units combine durability, precision, and safety to deliver reliable performance and low maintenance.

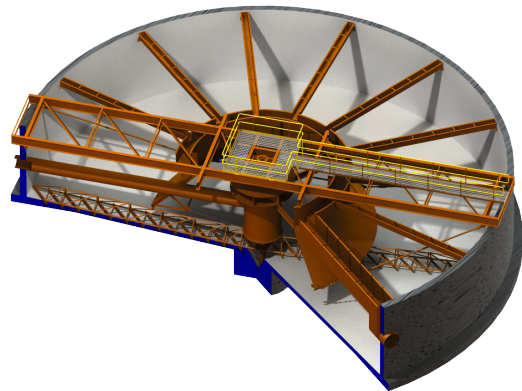
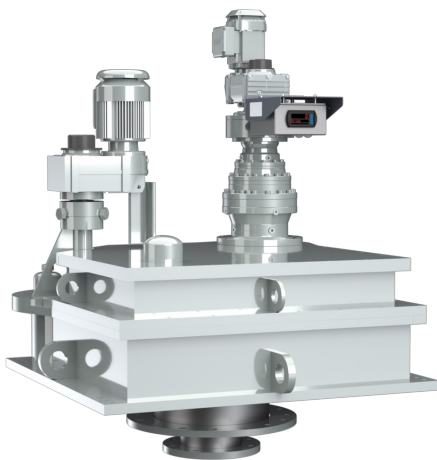

MODEL SELECTION

Engineered for solids contact clarifiers and thickeners, this unit features a full-span bridge and a central drive shaft. It comes in a range of models to meet varying torque requirements.

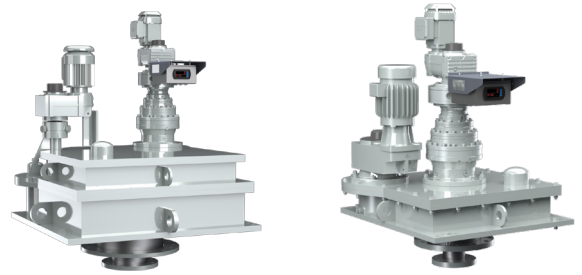

Rake Torque Capacity — Bridge-Mounted Dual Drives							Turbine Drive Power	
Model	Continuous		Maximum Overload		Yield		Allowable Horsepower	Maximum Speed
	ft-lbf	N-m	ft-lbf	N-m	ft-lbf	N-m		
SX-A*-D25	3,000	4,100	6,000	8,200	8,100	11,000	10	56
SX-B*-D25	6,000	8,200	12,000	16,400	16,200	22,000	10	56
SX-C*-D25	10,000	14,000	20,000	28,000	27,000	36,500	10	56
S25-A*-D25	14,000	19,000	28,000	38,000	54,000	73,000	20	56
S34-A*-D34	18,500	25,000	37,000	50,000	120,000	163,000	25	39
S34-B*-D34	27,000	36,500	54,000	73,000	120,000	163,000	25	39
S44-B*-D44	35,000	47,500	70,000	95,000	195,000	264,000	50	29
S44-C*-D44	51,000	69,000	102,000	138,000	195,000	264,000	50	29
S60-C*-D60	65,000	88,000	130,000	176,000	440,000	597,000	75	21
S60-D*-D60	125,000	170,000	250,000	340,000	440,000	597,000	75	21
S44-B*2-D44	70,000	95,000	140,000	190,000	390,000	528,000	50	29
S44-C*2-D44	102,000	138,000	204,000	276,000	390,000	528,000	50	29
S60-C*2-D60	130,000	176,000	260,000	352,000	880,000	1,194,000	75	21
S60-D*2-D60	250,000	340,000	500,000	678,000	880,000	1,194,000	75	21

Replace the * with the primary reducer option selected.
 Continuous: Torque at which main gear will have a life in excess of 20 years at normal operating speeds.
 Maximum Overload: The maximum safe, short term operating torque.
 Yield: The structural maximum torque based on the minimum yield strength of the main gear.

SX-D25 SERIES DIMENSIONS

Designed for smaller tanks with a full span bridge and center drive shaft, the SX-D25 Series drives feature a planetary gearbox with large tapered roller-bearings for the rake and a large combination gear-bearing for the turbine.

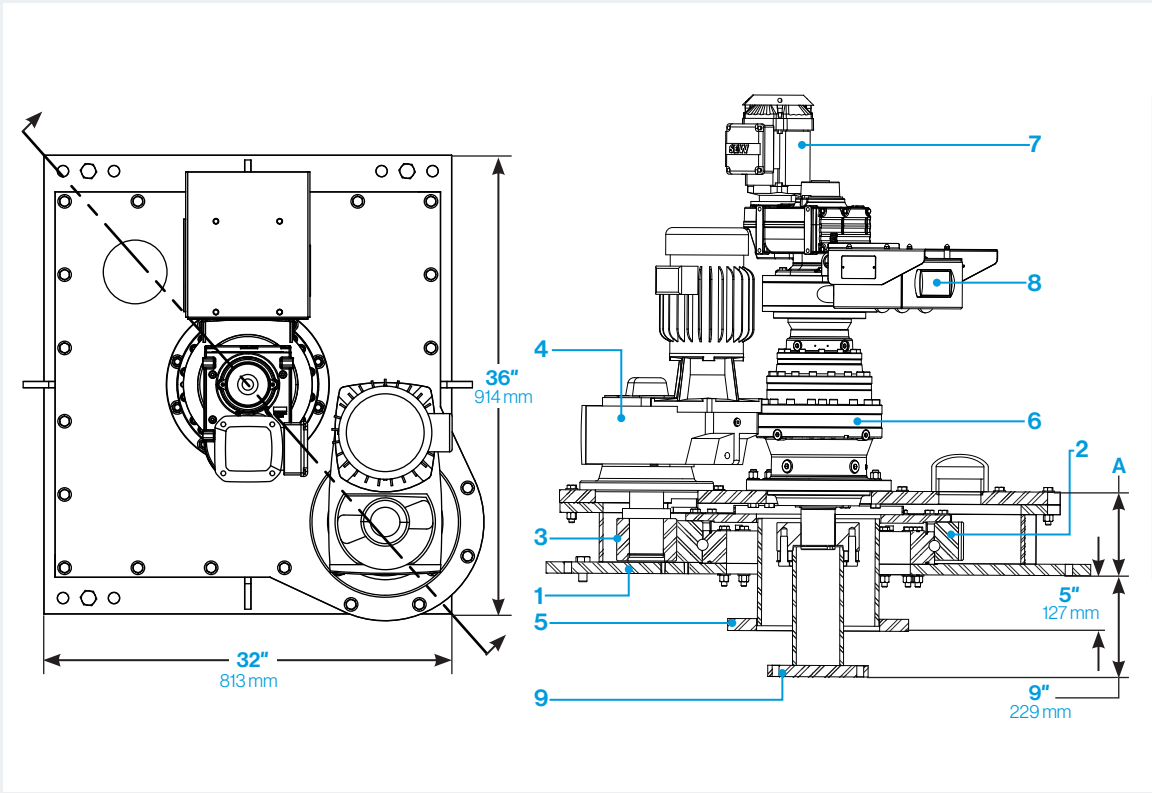

- ITEM DESCRIPTION
- 1. Machine Frame
 - 2. Main Gear-Bearing
 - 3. Pinion, Turbine
 - 4. Speed Reducer, Turbine
 - 5. Output Flange, Turbine
 - 6. Planetary Gearbox, Rake
 - 7. Primary Speed Reducer, Rake
 - 8. Torque Gauge Box, Rake
 - 9. Output Flange, Rake

Model	A		Rake Output Flange ¹	Turbine Output Flange ¹	Weight	
	in	mm			in	lb
SX-A*-D25	7.9	201	4	10	2,000	910
SX-B*-D25	7.9	201	4	10	2,200	1,000
SX-C*-D25	10.3	262	4 With oversized 15/16" dia. holes	10	2,500	1,140

¹ Metric flanges are available.
Replace * with the primary reducer option selected.

SD-SERIES DIMENSIONS

Designed for large tanks with a full span bridge and a center drive shaft, the SD-Series drives feature a precision high-capacity integral gear-bearing.

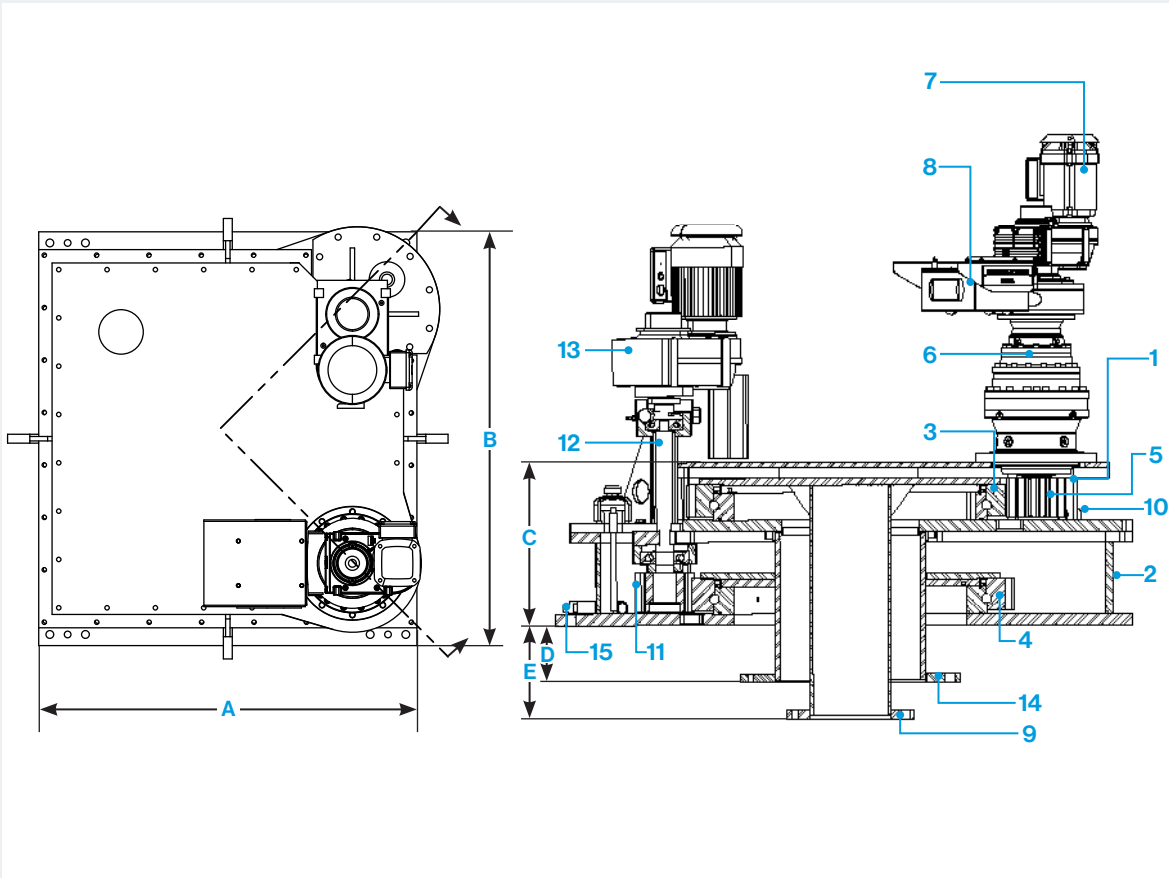

- ITEM DESCRIPTION
- 1. Machine Frame
 - 2. Main Gear Housing, Turbine
 - 3. Main Gear-Bearing, Rake
 - 4. Main Gear-Bearing, Turbine
 - 5. Pinion, Rake
 - 6. Planetary Gearbox, Rake
 - 7. Primary Speed Reducer, Rake
 - 8. Torque Gauge Box, Rake
 - 9. Output Flange, Rake
 - 10. Oil Drain, Rake
 - 11. Pinion, Turbine
 - 12. Turbine Drive-Bearing Adapter
 - 13. Helical Gearbox, Turbine
 - 14. Output Flange, Turbine
 - 15. Oil Drain, Turbine

Model	A		B		C		D		E		Rake Flange ¹	Turbine Flange ¹	Weight	
	in	mm	in	mm	in	mm	in	mm	in	mm	in	in	lb	kg
S25-A*-D	36	914	40	1,016	16.8	425	4	102	8	203	6	12	2,500	1,140
S34-A*-D	42.5	1,080	46.5	1,181	18.1	461	6	152	10	254	8	16	3,900	1,770
S34-B*-D	42.5	1,080	46.5	1,181	19.4	492	6	152	10	254	8	16	5,000	2,270
S44-B*-D	54	1,372	58	1,473	19.2	488	6	152	10	254	10	20	5,800	2,630
S44-C*-D	54	1,372	58	1,473	21.2	538	6	152	10	254	10	20	6,900	3,130
S60-C*-D	68	1,727	73	1,854	22.5	572	8	203	14	356	16	30	11,200	5,080
S60-D*-D	68	1,727	73	1,854	20.1	511	8	203	14	356	16	30	14,000	6,360

¹ Metric flanges are available.
 Replace * with the primary reducer option selected.

PRIMARY REDUCER OPTIONS

DBS drive units consist of several reducers: primary, secondary, and a final reduction unit that includes a pinion and integral gear-bearing for larger mechanisms. All reducers are directly coupled. A range of primary reduction units is available to meet customer requirements.

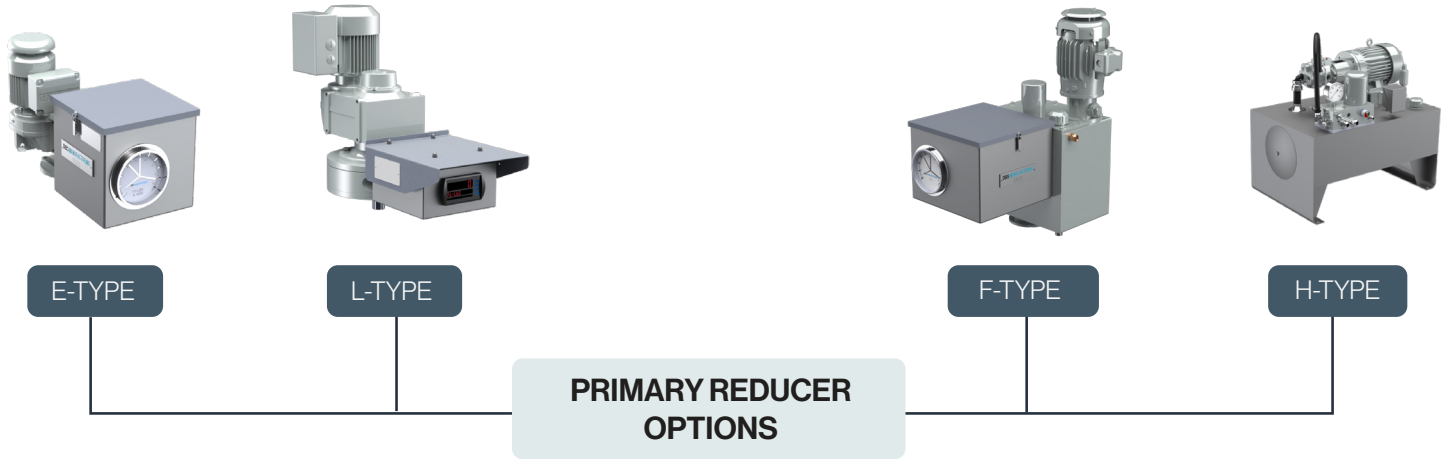

One of the reducers *above* will be assembled with one of the drive units *below*.

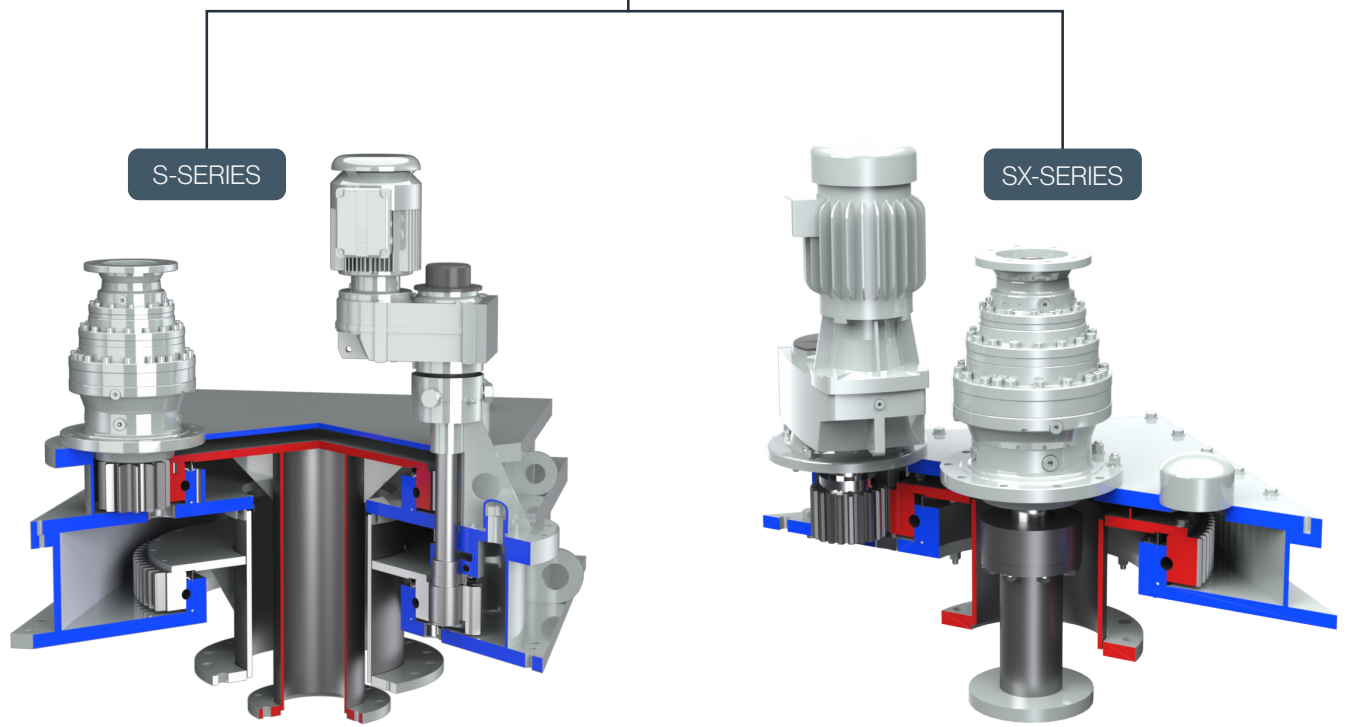

PRIMARY SPEED REDUCER OPTIONS

E-Type

The E-type design uses helical gears for speed reduction and includes alarm and cutoff switches, as well as a shear pin, providing triple protection for the drive unit. This design is employed when the output speed exceeds the limits of the F-type primary speed reducers or when an electro-mechanical drive unit is preferred.



L-Type

The L-type design features a helical gearbox for speed reduction, along with a digital torque meter and a solid-state torque sensor with no moving parts. It incorporates all the features of the E-type reducer and includes a 4-20 mA torque transducer as standard. This design is suitable for all applications.

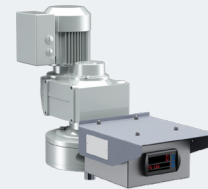

F-Type

The F-type design utilizes a hydraulic pump-motor combination for speed reduction. It features alarm and cutoff switches, as well as hydraulic relief, to provide triple protection for the drive unit. The design is positive torque-limiting and will operate under stalled and semi-stalled conditions. Optional reversing rotation and variable speed are also available.



H-Type

The H-type design incorporates all the features of the F-type primary speed reducer and uses a stand-alone industrial hydraulic power unit. This design is suitable for higher horsepower and multiple pinion drive applications.

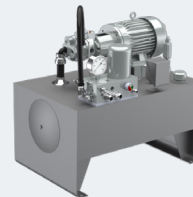

Turbine VARIABLE SPEED OPTIONS

Electrical Type Variable Speed Reducer

A variable frequency drive (VFD) controls the output speed of the electric motor. The VFD can be mounted near the drive unit or at a remote location, offering clean, maintenance-free, and economical variable speed control. Standard features include forward and reverse operation, speed indication, motor overload protection, soft-start, a 4-20 mA signal, and monitoring of operating conditions. These reducers provide a variable speed range of 5:1, or 10:1 with an inverter-duty motor.

ORDERING INFORMATION

Contact DBS or a DBS representative for assistance in deciding your equipment requirements.

DBS MANUFACTURING

dbsmfg.com/contact

404.768.2131

sales@dbsmfg.com

Bridge-Mounted Drive Unit Model Number					Turbine Specification Extension		
Series	Rake Gear Pitch Dia. (Inches)	Secondary Speed Reducer	Primary Speed Reducer	Number of Pinions	Turbine	Turbine Gear Pitch Dia. (Inches)	Maximum Turbine Horsepower
S	X for no final gear-bearing	A	E	(N/A)	D	25	5
		B	F				10
		C					10
	25	A	1 (omit) 2	10			
	34	A		25			
		B		50			
	44	B	E F H	50			
		C		75			
	60	C		75			
			D	75			
				4		60	75

Example:

MODEL S34-AF-D345 is for a bridge-mounted drive unit; 34 is the size of the final gear pitch diameter in inches; A is the size of the secondary speed reducer; F is the type of primary reducer; D is for a turbine drive; 34 is the size of the turbine gear pitch diameter in inches; 5 is the turbine horsepower.

Features

DBS bridge-mounted dual concentric output drive units come standard with alarm and cutoff switches for enhanced safety, a PDF O&M manual, and a 6-inch torque gauge that accurately indicates real torque on E and F-type primary reducers. The L-type reducer includes a digital torque display for precise torque measurement.

DBS also offers a range of optional features, including 4-20 mA torque and lift position transducers, bi-directional operation for L, F, and H-type reducers, loss motion switches, variable speed control on the turbine and/or the rake, explosion proof switches, and special coatings. Additional options include an oil heater for F and H-type reducers as well as the main gear housing, an oil temperature switch, and stainless steel construction for enhanced durability.

Visit dbsmfg.com for more information.

DBS[®] MANUFACTURING

- Clarifier & Thickener Drives
- Hyperbolic Mixers
- Low-Speed Surface Aerators
- Rotary Distributor Center Mechanisms

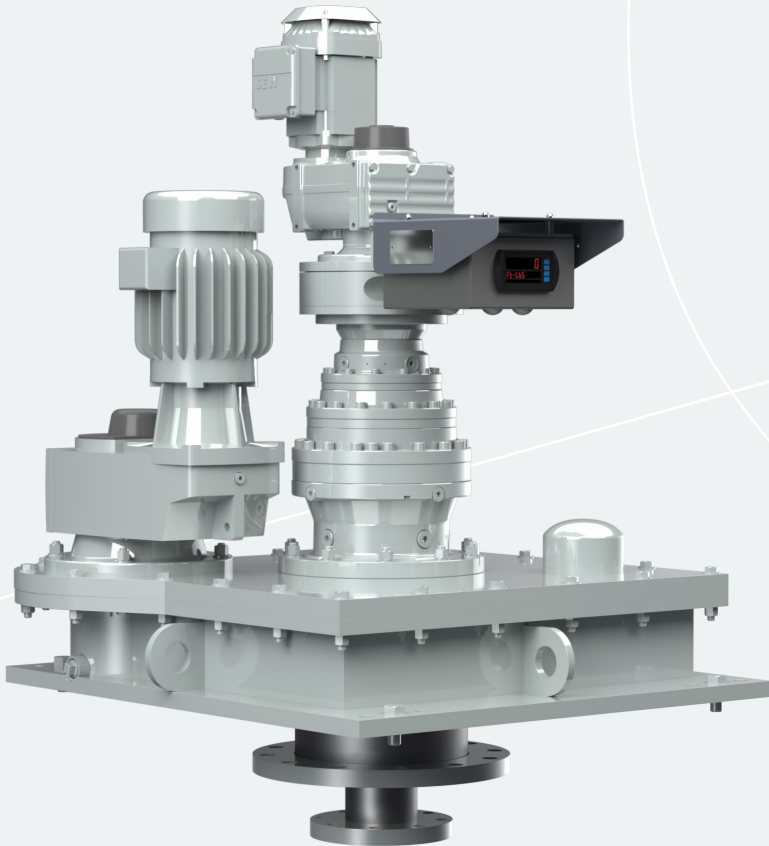

Bridge-Mounted
Dual Concentric

SX-D25-SERIES
MODEL SX-AL-D25

dbsmfg.com
404.768.2131
sales@dbsmfg.com

45 SouthWoods Parkway
Atlanta, Georgia 30354