

# DBS MANUFACTURING

ENGINEERED FIRSTS | BUILT TO LAST

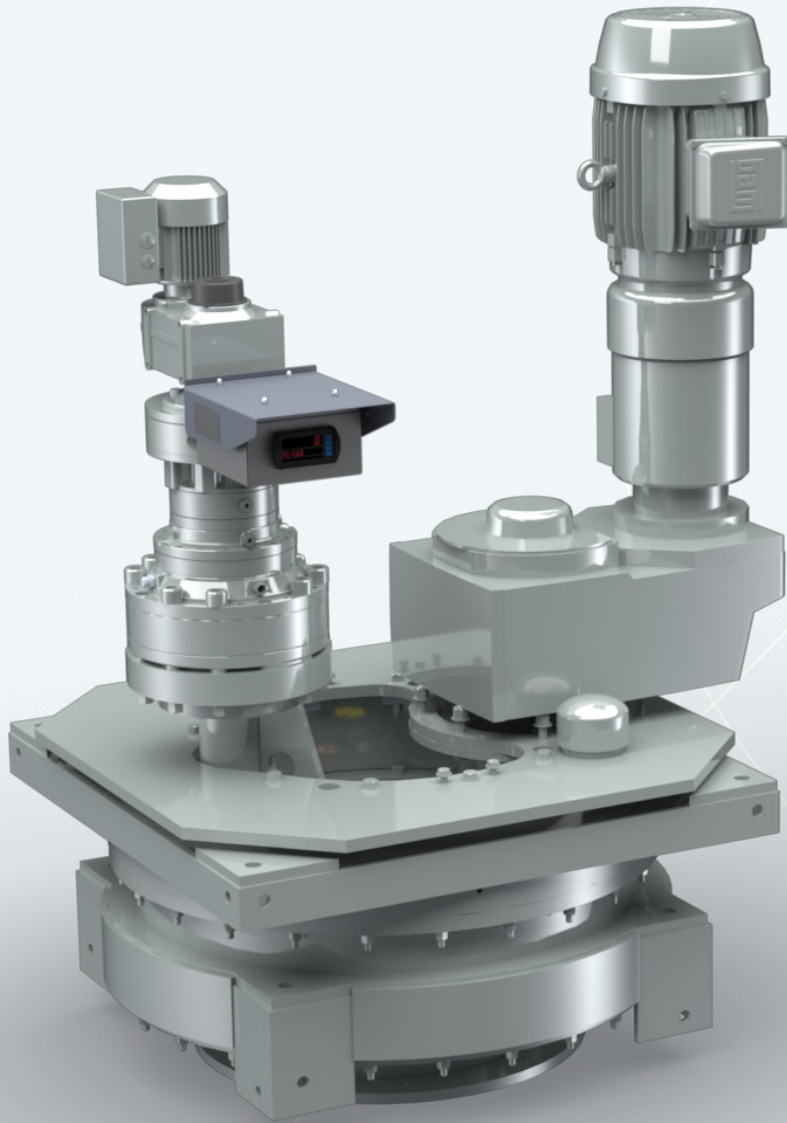

Pier-Mounted | Dual Concentric  
DRUM OUTPUT DRIVE UNITS

## DBS MANUFACTURING, INC.

DBS Manufacturing is a successful, privately held business that designs, manufactures, and provides application engineering for products sold to original equipment manufacturers, end users, and municipal and industrial facilities around the world.

### Center Pier-Mounted Dual Concentric Output Shaft Drive Units

These DBS drive units feature two concentric output drive drums for use in solids contact and flocculating clarifiers or softeners. Ideal for industrial, municipal, and mining clarifiers and thickeners, they typically are used on tanks ranging from 40 to 300 feet (12 to 100 meters) in diameter with a center pier and half-bridge.

The turbine drive section is built as a heavy-duty, higher-speed, fully enclosed gear drive, while the rake drive section operates at low speed with high torque, demanding environments. A central column supports the drive unit within the tank, which includes an external rotating drive drum equipped with attachment points for the rake cage.

Designed with longevity in mind, the unit features a forged alloy steel main gear and pinion engineered for a lifespan of 20 years, alongside a precision, four-point-contact main bearing with a 10-year warranty. Additionally, the unit boasts a permanently lubricated rake intermediate gearbox, ensuring reliability and reduced downtime.

For ease of operation, the rake drive incorporates an accurate torque gauge that can be calibrated in your preferred units. The system is equipped with dry well lubrication on the turbine output and includes a variable speed turbine drive as a standard feature. Safety is also a priority, with alarm and cutoff switches, as well as mechanical torque limiting via a shear pin or pressure relief valve.

In summary, the dual shaft drive units combine durability, precision, and safety to deliver reliable performance and low maintenance.

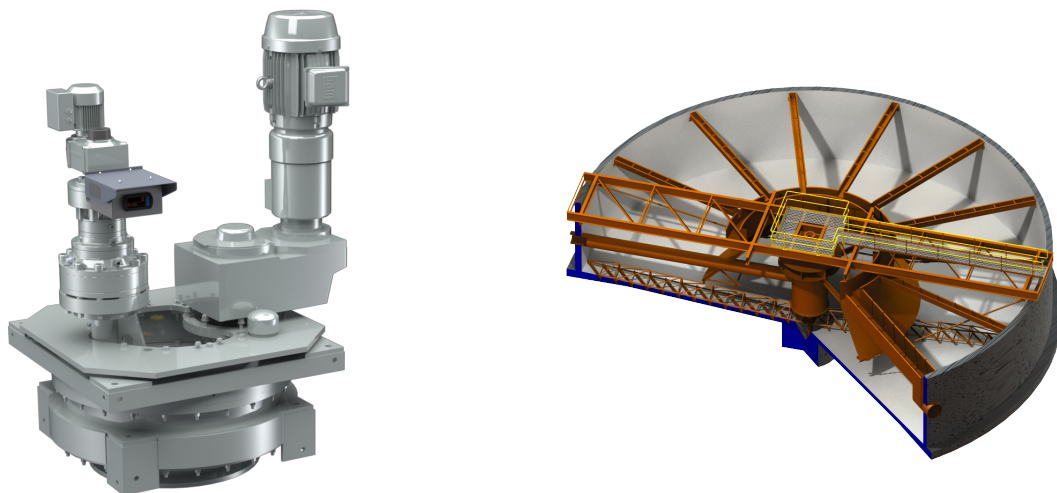

## MODEL SELECTION

The DD-Series, designed for clarifiers and thickeners with a center column, half bridge, and rake cage, offers a wide range of models to accommodate varying torque requirements.



### Rake Torque Capacity — Pier-Mounted Dual Drive Units

### Turbine Drive Power

Model	Continuous		Maximum Overload		Yield		Allowable <i>Horsepower</i>	Maximum Speed <i>rpm</i>
	<i>ft-lbf</i>	<i>N-m</i>	<i>ft-lbf</i>	<i>N-m</i>	<i>ft-lbf</i>	<i>N-m</i>		
D30-A*-D30	16,000	22,000	32,000	44,000	94,000	127,000	25	32
D30-B*-D30	27,000	36,500	54,000	73,000	94,000	127,000	25	32
D42-B*-D42	35,000	47,500	70,000	95,000	195,000	264,000	50	24
D42-C*-D42	51,000	69,000	102,000	138,000	195,000	264,000	50	24
D60-C*-D60	65,000	88,000	130,000	176,000	440,000	597,000	75	17
D60-D*-D60	125,000	170,000	250,000	339,000	440,000	597,000	75	17
D80-E*-D80	350,000	475,000	700,000	950,000	950,000	1,290,000	100	13
D42-B*2-D42	70,000	95,000	140,000	190,000	390,000	528,000	50	24
D42-C*2-D42	100,000	140,000	204,000	276,000	390,000	528,000	50	24
D60-C*2-D60	130,000	176,000	260,000	350,000	880,000	1,194,000	75	17
D60-D*2-D60	250,000	340,000	500,000	680,000	880,000	1,194,000	75	17
D80-E*2-D80	700,000	950,000	1,400,000	1,900,000	1,900,000	2,580,000	100	13

Replace the \* with the primary reducer option selected.  
 Continuous: Torque at which main gear will have a life in excess of 20 years at normal operating speeds.  
 Maximum Overload: The maximum safe, short term operating torque.  
 Yield: The structural maximum torque based on the minimum yield strength of the main gear.

## DD-SERIES DIMENSIONS

Designed for large tanks with a half-bridge and dual concentric output drive shafts, the DD-Series drives feature a robust combination of internal gears and precision ball-bearings for both the rake and turbine sections.

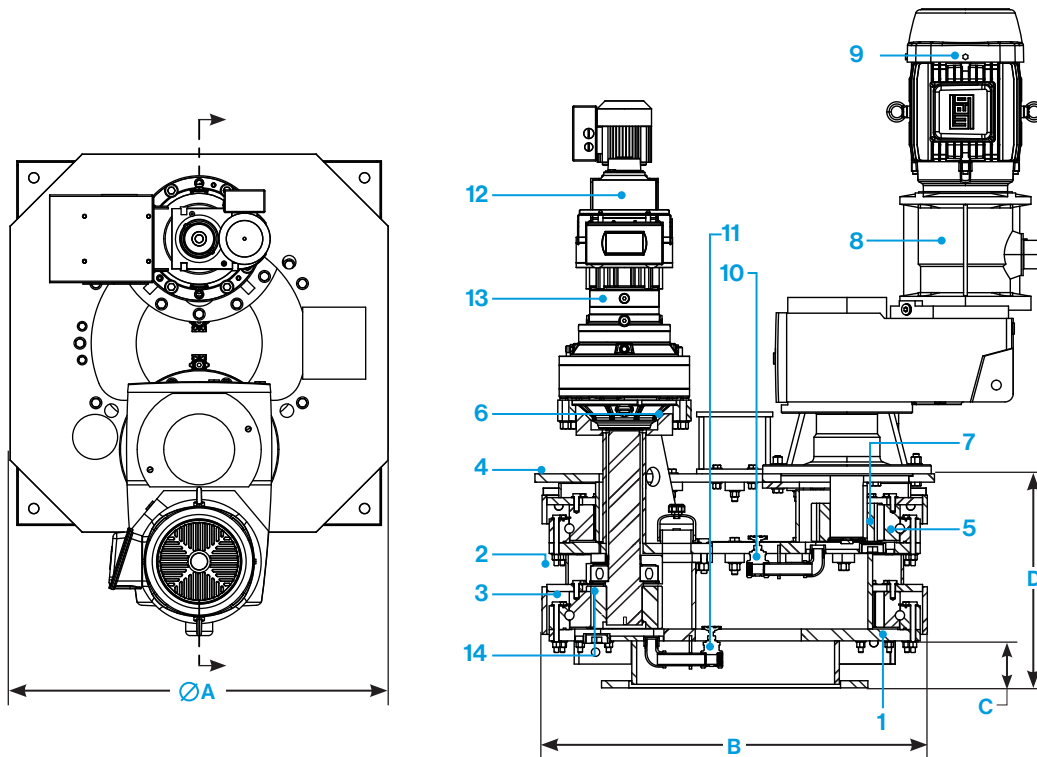

- ITEM DESCRIPTION
1. Machine Frame
  2. Drive Drum, Rake
  3. Main Gear-Bearing, Rake
  4. Drive Drum, Turbine
  5. Main Gear-Bearing, Turbine
  6. Rake Pinion Drive Adapter
  7. Pinion Turbine
  8. Primary Speed Reducer, Turbine
  9. Electrical Motor, Turbine
  10. Oil Drain Assembly, Turbine
  11. Oil Drain Assembly, Rake
  12. Primary Speed Reducer, Rake
  13. Planetary Gearbox, Rake
  14. Pinion, Rake

Model	A		B		C		D		Standard Mounting Flange		Weight	
	in	mm	in	mm	in	mm	in	mm	in	mm	lb	kg
D30-A*-D	48	1,219	47	1,194	5	127	14.25	362	32	813	5,200	2,359
D30-B*-D	48	1,219	47	1,194	5	127	14.25	362	32	813	6,400	2,903
D42-B*-D	60	1,524	60	1,524	5	127	14.5	368	44	1,118	8,000	3,629
D42-C*-D	60	1,524	60	1,524	5	127	14.5	368	44	1,118	8,600	3,901
D60-C*-D	84	2,134	80	2,032	6	152	17.75	451	62	1,575	12,800	5,806
D60-D*-D	84	2,134	80	2,032	6	152	17.75	451	62	1,575	14,800	6,713

Replace \* with the primary reducer option selected.

## PRIMARY REDUCER OPTIONS

DBS drive units consist of several reducers: primary, secondary, and a final reduction unit that includes a pinion and integral gear-bearing for larger mechanisms. All reducers are directly coupled. A range of primary reduction units is available to meet customer requirements.

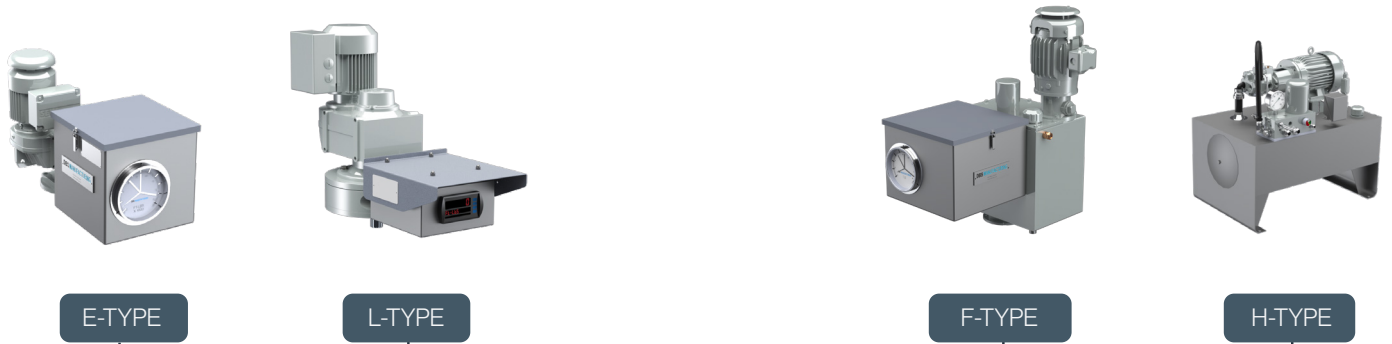

E-TYPE

L-TYPE

F-TYPE

H-TYPE

**PRIMARY REDUCER  
OPTIONS**

**DD-SERIES**

REDUCER

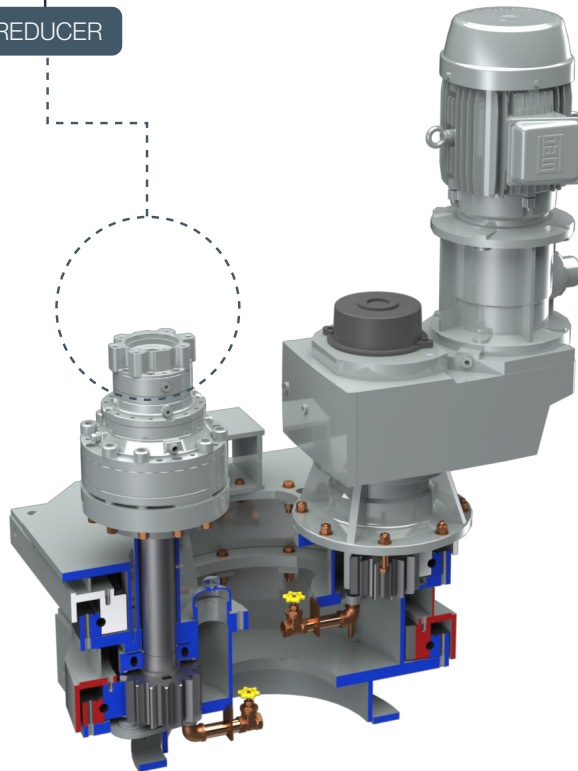

## PRIMARY SPEED REDUCER OPTIONS

### E-Type

The E-type design uses helical gears for speed reduction and includes alarm and cutoff switches, as well as a shear pin, providing triple protection for the drive unit. This design is employed when the output speed exceeds the limits of the F-type primary speed reducers or when an electro-mechanical drive unit is preferred.



### L-Type

The L-type design features a helical gearbox for speed reduction, along with a digital torque meter and a solid-state torque sensor with no moving parts. It incorporates all the features of the E-type reducer and includes a 4-20 mA torque transducer as standard. This design is suitable for all applications.

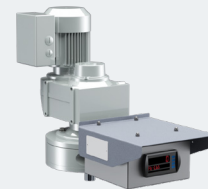

### F-Type

The F-type design utilizes a hydraulic pump-motor combination for speed reduction. It features alarm and cutoff switches, as well as hydraulic relief, to provide triple protection for the drive unit. The design is positive torque-limiting and will operate under stalled and semi-stalled conditions. Optional reversing rotation and variable speed are also available.



### H-Type

The H-type design incorporates all the features of the F-type primary speed reducer and uses a stand-alone industrial hydraulic power unit. This design is suitable for higher horsepower and multiple pinion drive applications.



## Turbine VARIABLE SPEED OPTIONS

### Electrical Type Variable Speed Reducer

A variable frequency drive (VFD) controls the output speed of the electric motor. The VFD can be mounted near the drive unit or at a remote location, offering clean, maintenance-free, and economical variable speed control. Standard features include forward and reverse operation, speed indication, motor overload protection, soft-start, a 4-20 mA signal, and monitoring of operating conditions. These reducers provide a variable speed range of 5:1, or 10:1 with an inverter-duty motor.

## ORDERING INFORMATION

Contact DBS or a DBS representative for assistance in deciding your equipment requirements.

### DBS MANUFACTURING

[dbsmfg.com/contact](https://dbsmfg.com/contact)  
 404.768.2131  
[sales@dbsmfg.com](mailto:sales@dbsmfg.com)

Pier-Mounted Drive Unit Model Number					Turbine Specification Extension		
Series	Rake Gear Pitch Dia. (Inches)	Secondary Speed Reducer	Primary Speed Reducer	Number of Pinions	Turbine	Turbine Gear Pitch Dia. (Inches)	Maximum Turbine Horsepower
D	30	A	E F H	1 (omit)	D	30	25
		B				42	50
	42	B		1 (omit) 2		42	50
		C				60	75
	60	C		1 (omit) 2 3 4		60	75
		D				80	100
	80	D		80		100	
		E					

#### Example:

**MODEL D30-AF-D3015 D** is for a pier-mounted drive unit; 30 is the size of the final rake gear pitch in inches; A is the size of the secondary speed reducer; F is the primary reducer type; D is for turbine drive; 30 is the size of the turbine gear pitch diameter in inches; 15 is the turbine horsepower.

## Features

DBS pier-mounted drive units come standard with alarm and cutoff switches for enhanced safety, a PDF O&M manual, and 6-inch torque gauge that accurately indicates real torque on E and F-type primary reducers. The L-type reducer includes a digital torque display for precise torque measurement. All torque gauges can be calibrated your desired units.

DBS also offers a range of optional features, including 4-20 mA torque and lift position transducers, bi-directional operation for L, F, and H-type reducers, loss motion switches, variable speed control, explosion proof switches, and special coatings. Additional options include an oil heater for F and H-type reducers, an oil temperature switch, oil level switch, condensate control unit, and stainless steel construction for enhanced durability.

Visit [dbsmfg.com](https://dbsmfg.com) for more information.

# DBS<sup>®</sup> MANUFACTURING

- Clarifier & Thickener Drives
- Hyperbolic Mixers
- Low-Speed Surface Aerators
- Rotary Distributor Center Mechanisms



Pier-Mounted  
Dual Concentric | DD-SERIES  
MODEL D30-BL-D30

[dbsmfg.com](http://dbsmfg.com)  
404.768.2131  
[sales@dbsmfg.com](mailto:sales@dbsmfg.com)

45 SouthWoods Parkway  
Atlanta, Georgia 30354