

Bridge-Mounted Drive Units

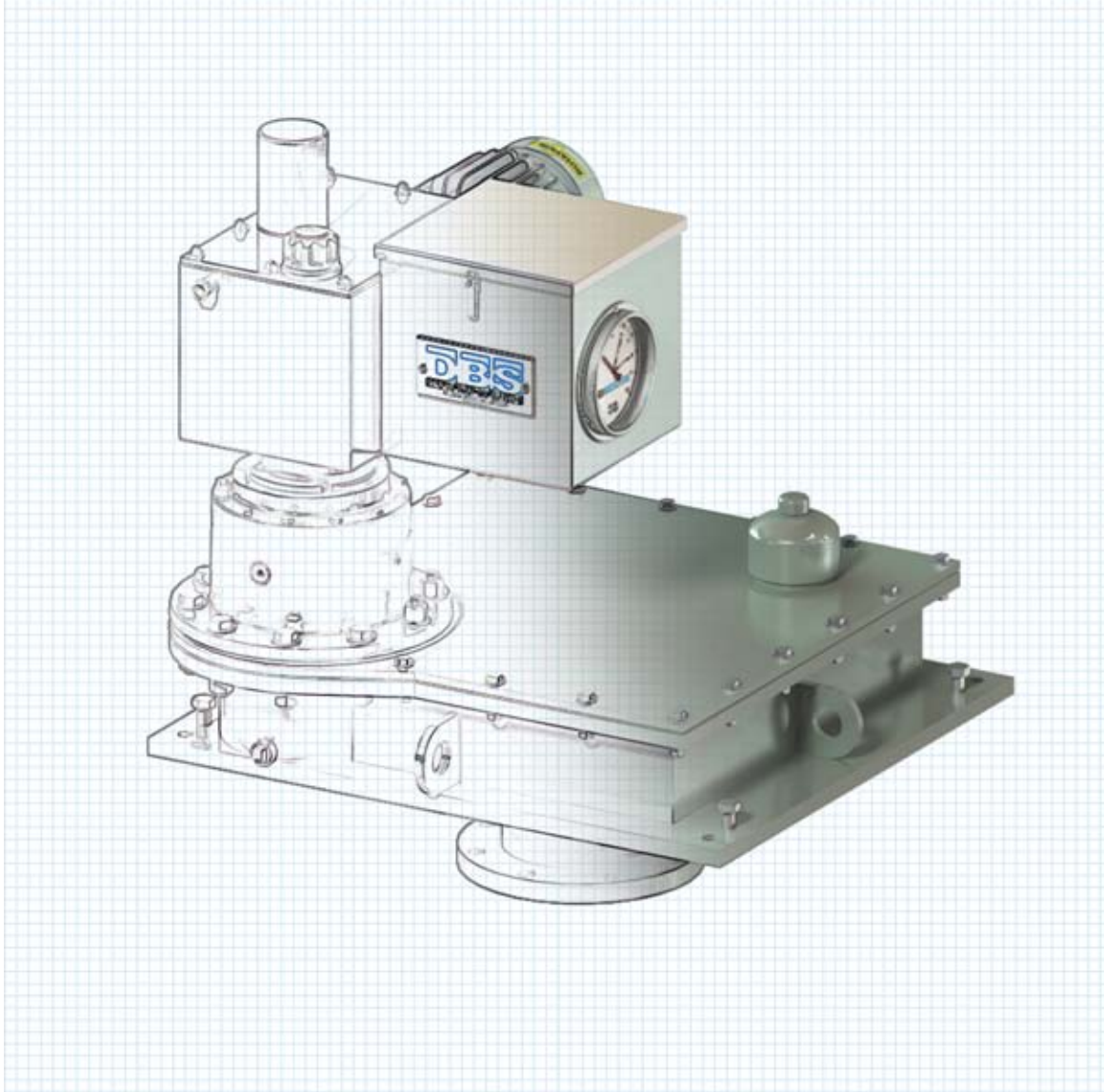

DBS MANUFACTURING®

Bridge-Mounted Drive Units

Description

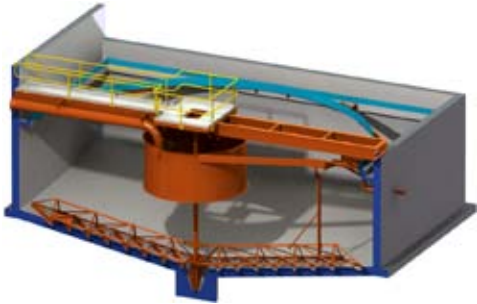

- A low-speed, high-torque, totally enclosed gear drive with positive overload protection
- The drive unit is supported by a bridge completely spanning the tank
- The drive unit has a central output shaft to drive the rakes
- Used in industrial, municipal and mining clarifiers and thickeners
- Typically used on tank sizes from 10 to 100 ft (3 to 30 m) in diameter

Features



- Forged alloy steel main gear and pinion designed for 20 years of life calculated per AGMA 2001-C95
- Precision, four-point-contact main bearing, with a 10-year warranty
- Accurate torque gauge calibrated in ft-lbf, N-m or any units desired
- Alarm and cutoff switches and maximum torque limiting via shear pin or pressure relief valve
- No lower pinion bearing, eliminating a common source of drive failure
- Designed for minimum maintenance with permanently lubricated intermediate reducer

TORQUE CAPACITIES - BRIDGE-MOUNTED DRIVE UNITS

| Model | Continuous | | Maximum Overload | | Yield | |
|---------|------------|---------|------------------|-----------|-----------|-----------|
| | ft-lbf | N-m | ft-lbf | N-m | ft-lbf | N-m |
| SX-A* | 3,000 | 4,100 | 6,000 | 8,200 | 8,100 | 11,000 |
| SX-B* | 6,000 | 8,200 | 12,000 | 16,400 | 16,200 | 22,000 |
| SX-C* | 10,000 | 14,000 | 20,000 | 28,000 | 27,000 | 36,500 |
| S25-A* | 14,000 | 19,000 | 28,000 | 38,000 | 54,000 | 73,000 |
| S34-A* | 18,500 | 25,000 | 37,000 | 50,000 | 120,000 | 163,000 |
| S34-B* | 27,000 | 36,500 | 54,000 | 73,000 | 120,000 | 163,000 |
| S44-B* | 35,000 | 47,500 | 70,000 | 95,000 | 195,000 | 264,000 |
| S44-C* | 47,000 | 64,000 | 94,000 | 128,000 | 195,000 | 264,000 |
| S60-C* | 65,000 | 88,000 | 130,000 | 176,000 | 440,000 | 597,000 |
| S60-D* | 125,000 | 169,500 | 250,000 | 339,000 | 440,000 | 597,000 |
| S80-D* | 140,000 | 190,000 | 280,000 | 380,000 | 750,000 | 1,017,000 |
| S80-E* | 250,000 | 339,000 | 500,000 | 678,000 | 750,000 | 1,017,000 |
| S44-B*2 | 70,000 | 95,000 | 140,000 | 190,000 | 390,000 | 528,000 |
| S44-C*2 | 94,000 | 128,000 | 188,000 | 256,000 | 390,000 | 528,000 |
| S60-C*2 | 130,000 | 176,000 | 260,000 | 352,000 | 880,000 | 1,194,000 |
| S60-D*2 | 250,000 | 339,000 | 500,000 | 678,000 | 880,000 | 1,194,000 |
| S80-D*2 | 280,000 | 380,000 | 560,000 | 760,000 | 1,500,000 | 2,034,000 |
| S80-E*2 | 500,000 | 678,000 | 1,000,000 | 1,356,000 | 1,500,000 | 2,034,000 |

Replace the * with the primary reducer option selected.

Continuous: Torque at which main gear will have a life in excess of 20 years at normal operating speeds.

Maximum Overload: The maximum safe, short term operating torque.

Yield: The structural maximum torque based on the minimum yield strength of the main gear.

Bridge-Mounted Drive Units

SX-Series Dimensions



- | Item | Description |
|------|-----------------------|
| 1 | Machine Frame |
| 2 | Planetary Gearbox |
| 3 | Torque Gauge Assembly |
| 4 | Primary Speed Reducer |
| 5 | Output Flange |

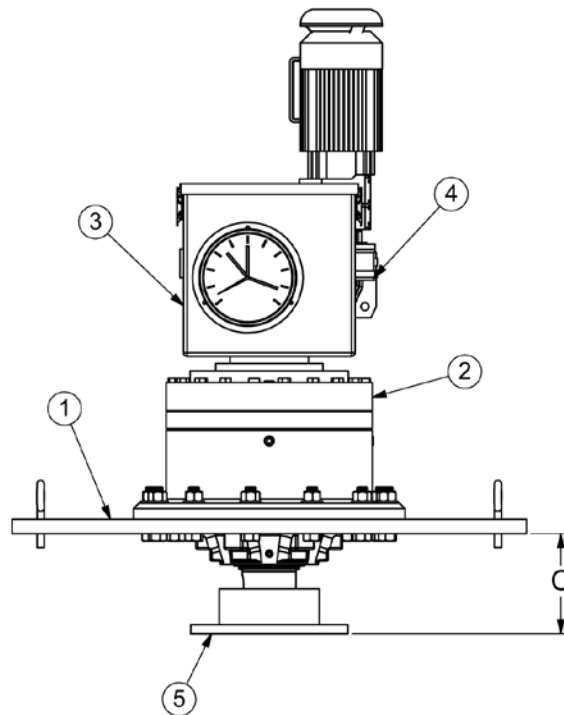
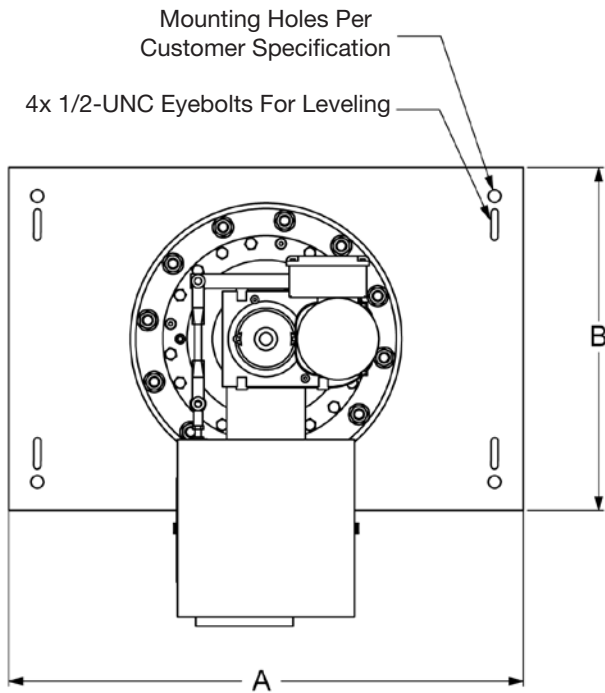

| Model | A | | B | | C | | Output Flange ¹ | Weight | |
|-------|----|-----|----|-----|-----|-----|----------------------------|--------|-----|
| | in | mm | in | mm | in | mm | | lb | kg |
| SX-A* | 36 | 914 | 24 | 610 | 5.2 | 132 | 4" | 700 | 318 |
| SX-B* | 36 | 914 | 24 | 610 | 7 | 178 | 6" | 900 | 410 |
| SX-C* | 36 | 914 | 24 | 610 | 8.6 | 218 | 6" | 1,200 | 545 |

¹ Metric flanges are available.
Replace the * with the primary reducer option selected.

Bridge-Mounted Drive Units

S-Series Dimensions



- | Item | Description |
|------|-----------------------|
| 1 | Machine Frame |
| 2 | Main Gearbearing |
| 3 | Pinion |
| 4 | Planetary Gearbox |
| 5 | Primary Speed Reducer |
| 6 | Torque Gauge Assembly |
| 7 | Output Flange |
| 8 | Drain Plug |

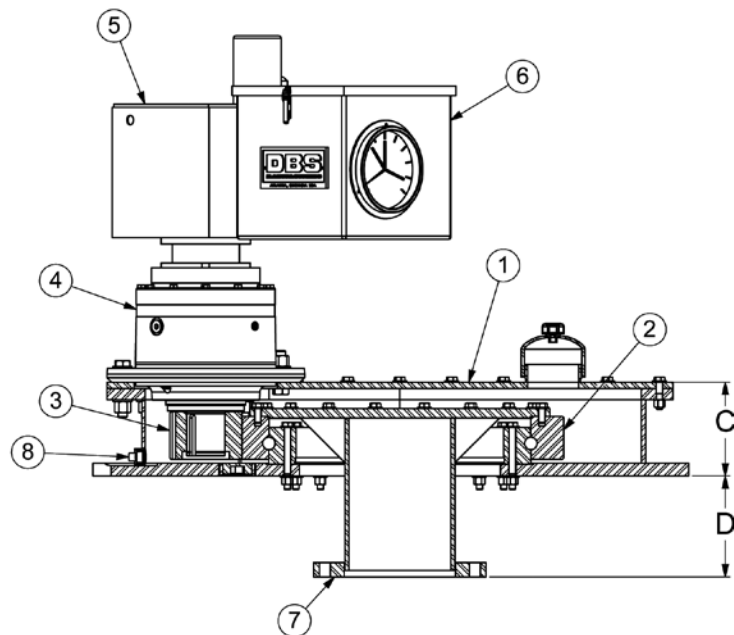
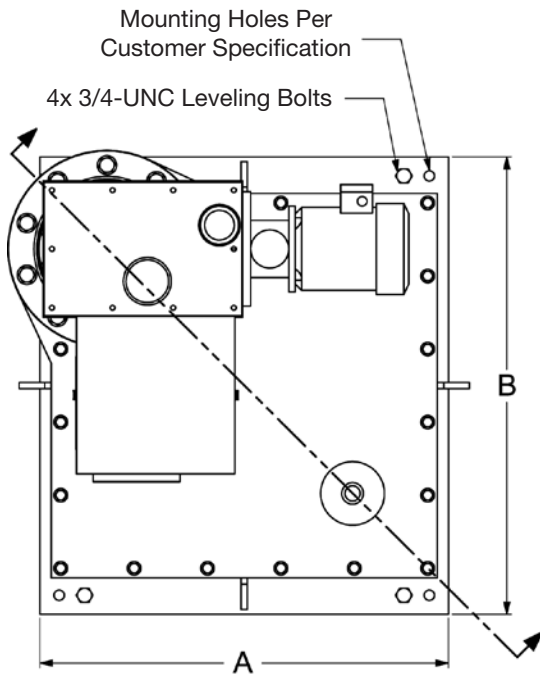

| Model | A | | B | | C | | D | | Output Flange ¹ | Weight | |
|--------|------|-------|------|-------|------|-----|----|-----|----------------------------|--------|-------|
| | in | mm | in | mm | in | mm | in | mm | | lb | kg |
| S25-A* | 32 | 813 | 36 | 914 | 7.4 | 188 | 8 | 203 | 6" | 1,340 | 610 |
| S34-A* | 39.5 | 1,003 | 43.5 | 1,105 | 8.1 | 207 | 8 | 203 | 8" | 1,940 | 880 |
| S34-B* | 42.5 | 1,080 | 46.5 | 1,180 | 9.4 | 239 | 8 | 203 | 8" | 2,340 | 1,060 |
| S44-B* | 50 | 1,270 | 55 | 1,397 | 9.3 | 236 | 10 | 254 | 10" | 2,920 | 1,330 |
| S44-C* | 54 | 1,372 | 59 | 1,499 | 11.3 | 287 | 10 | 254 | 10" | 3,500 | 1,590 |
| S60-C* | 66 | 1,676 | 70 | 1,778 | 11.5 | 292 | 12 | 305 | 18" | 5,000 | 2,270 |
| S60-D* | 68 | 1,727 | 73 | 1,854 | 10.1 | 258 | 12 | 305 | 18" | 5,600 | 2,540 |
| S80-D* | 96 | 2,438 | 104 | 2,642 | 13.5 | 343 | 14 | 356 | 24" | 10,800 | 4,910 |

¹ Metric flanges are available.

Replace the * with the primary reducer option selected.

Bridge-Mounted Drive Units

Primary Reducer Option

W-Type



E-Type



F-Type



H-Type

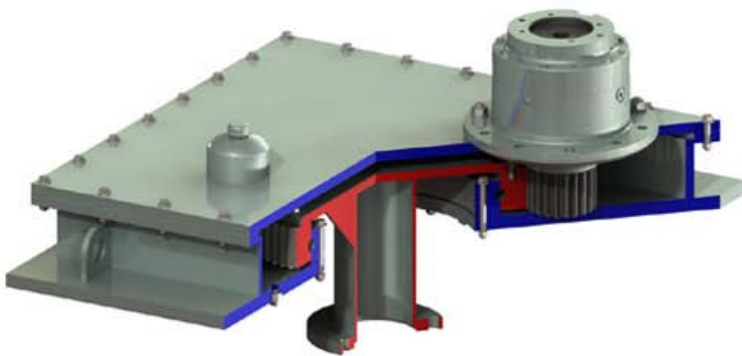
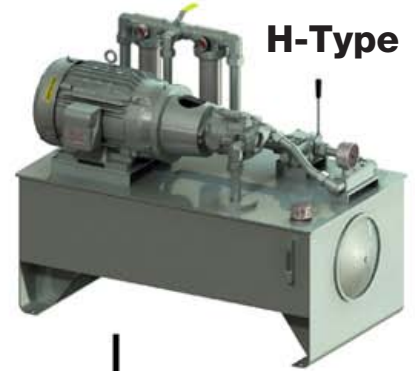

S-Series

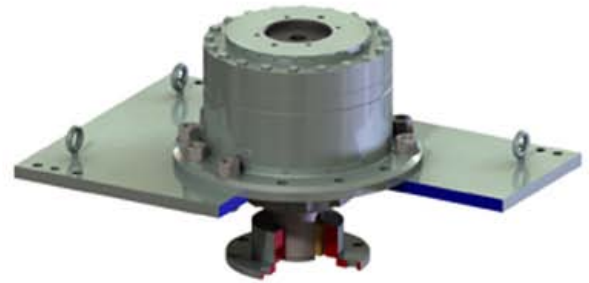

SX-Series

One of the items above will be used with one of the items below to make a complete drive unit assembly.

Bridge-Mounted Drive Units

Primary Reducer Option

E-type primary speed reducer

The E-type design uses helical gears for speed reduction. It has alarm and cutoff switches and a shear pin to provide triple protection of the drive unit. This design is used where the output speed is outside the limits of the F-type primary speed reducers or when an electro-mechanical type drive unit is desired.



F-type primary speed reducer

The F-type design uses a hydraulic pump-motor combination for speed reduction. It has alarm and cutoff switches and hydraulic relief (equivalent to a shear pin in the E-type primary speed reducer) to provide triple protection of the drive unit. This design is positive torque-limiting and will operate under stalled and semi-stalled conditions. Optional reversing rotation and variable speed are available. The torque indication and protection system is equally accurate for operation in either direction.



H-type primary speed reducer

The H-type design has all the features of the F-type primary speed reducer. It uses a stand-alone industrial hydraulic power unit. This design is used on higher horsepower and multiple pinion drive applications.



W-type primary speed reducer

The W-type design uses helical gears for speed reduction. It has shear pin and shear pin activated cutoff switch to protect the drive unit. This is simplified E-type design used where a torque gauge and adjustable alarm switch are not required.



Bridge-Mounted Drive Units

Lift Mechanism Option



The lift mechanism provides the ability to raise and lower the rakes. The rake lift operates by raising the output shaft into the drive unit. Rake vertical displacement of up to 36 inches (900 mm) can be provided.

The lift mechanism is fully contained within the drive unit. In most cases, the installation of a DBS lift-equipped drive unit is no more complicated than that of a normal non-lifting clarifier drive.

The lift option is offered with manual or powered operation. The powered lift mechanism provides positive lift force control to prevent damage to the rakes or the screw jack.

The DBS powered lift design does not require the lift mechanism to rotate. There are no rotary electrical slip rings to maintain.

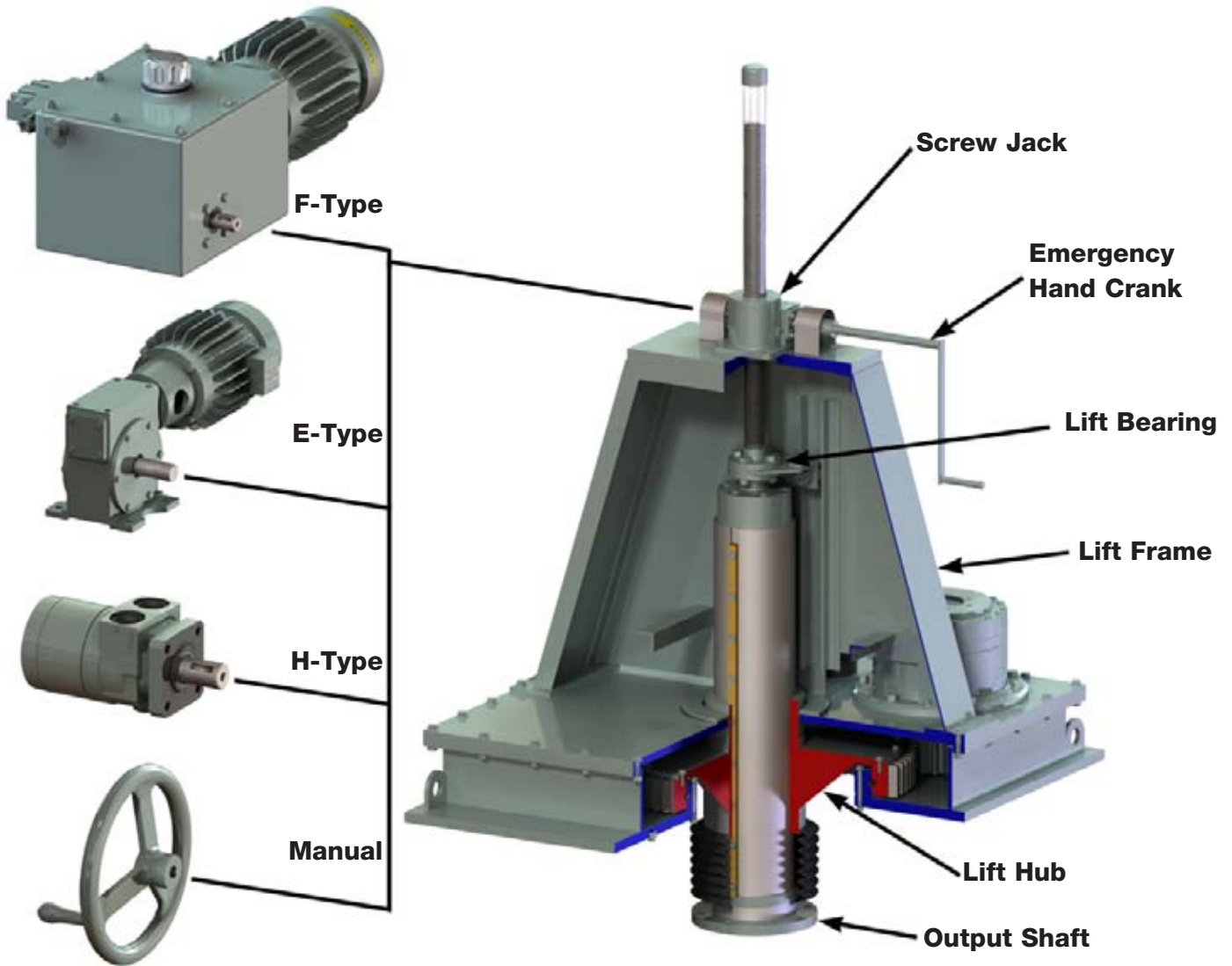

F-Type Lift Actuator: A totally enclosed hydraulic speed reducer power the lift jack.

E-Type Lift Actuator: The actuator utilizes a series of mechanical speed reducers to power the lift jack.

H-Type Lift Actuator: A hydraulic motor, powered by the rake primary reducer, operates the lift jack.

Bridge-Mounted Drive Units

Ordering Information

| Bridge-Mounted Drive Unit Model Number | | | | | Lift Option Specification Extension | | | | | |
|--|-------------------------------|---|-------------------------|-----------------------|-------------------------------------|-------|-----------------|----------------------|----------------------|----------------------|
| Series | Rake Gear Pitch Dia. (inches) | - | Secondary Speed Reducer | Primary Speed Reducer | Number of Pinions | - | Lift Option | Lift Capacity (tons) | Lift Travel (inches) | Lift Actuator Option |
| S | X for no final gear-bearing | | A | E | (N/A) | | L | 5 | 12 | M, E, F |
| | | | B | F | | | | 24 | | |
| | | | C | | | (N/A) | (N/A) | (N/A) | (N/A) | |
| | 25 | | A | E F H | 1 (omit) 2 | L | 5 | 12 | M E F H | |
| | 34 | | A | | | | 10 | 24 | | |
| | | | B | | | | 15 | 36 | | |
| | 44 | | B | | | | 15 | | | |
| | | | C | | | | 20 | | | |
| | | | C | | | | 25 | | | |
| | 60 | | D | 3 | | | | | | |
| | | | D | 4 | | | | | | |
| | 80 | | D | | | | | | | |
| | | E | | | | | Consult Factory | Consult Factory | Consult Factory | |

Example: Model S34-AF-L1012F

S is for a bridge-mounted drive unit; 34 is the size of the final gear pitch diameter in inches; A is the size of the secondary speed reducer; F is the type of the primary reducer; L is for a lift mechanism; 10 is the lift capacity in tons; 12 is the lift travel in inches; F is the type of the lift actuator.

Standard Features

- Alarm and cutoff switches
- O&M manual in PDF format
- 6" torque gauge indicating real torque
(not available on H-type primary reducer)

Optional Features

- 4-20 mA torque transducer
- Bi-directional operation (available for F and H-type primary reducers)
- Loss motion switch
- 4-20 mA lift position transducer
- Variable speed
- Explosion proof switches
- Special coating
- Oil heater (available for F and H-type primary reducers and main gear housing)
- Special electric motor
- Oil temperature switch
- Oil level switch



**Bridge-Mounted Drive Units
Model S25-AF**

Clarifier & Thickener Drives

Retrofits

Low-Speed Surface Aerators

Rotary Distributor Center Mechanisms

DBS Manufacturing, Incorporated
45 SouthWoods Parkway, Atlanta, Georgia 30354 USA
404.768.2131 phone 404.761.6360 fax
www.dbsmfg.com email: engineering@dbsmfg.com