

Pier-Mounted

Dual Concentric Drum Output Drive Units



DBS MANUFACTURING®

Pier-Mounted Dual Concentric Drum Output Drive Units

Introduction

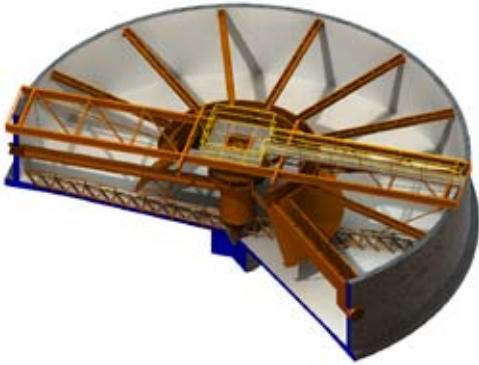

The DBS Pier-Mounted dual concentric drum output drive unit represents state of the art in reliability and performance. Two independent drive units are stacked concentrically together to drive a rake mechanism and a turbine. The rake drive is a low-speed, high-torque, totally enclosed gear drive with positive output torque overload protection. The turbine drive is a heavy-duty, higher speed, totally enclosed gear drive. The specially designed final output precision bearings provide superior life and reliability in excess of 100 years. The forged alloy steel gears and pinions are designed for a minimum life of 20 years.

DBS Pier-Mounted dual concentric drum output drive units are typically used on solids contact and flocculating clarifiers or softeners. The drive unit is supported by a column in the center of the tank. DBS drive units are mounted on tanks that range from 40 to 300 feet (12 to 100 m) in diameter.

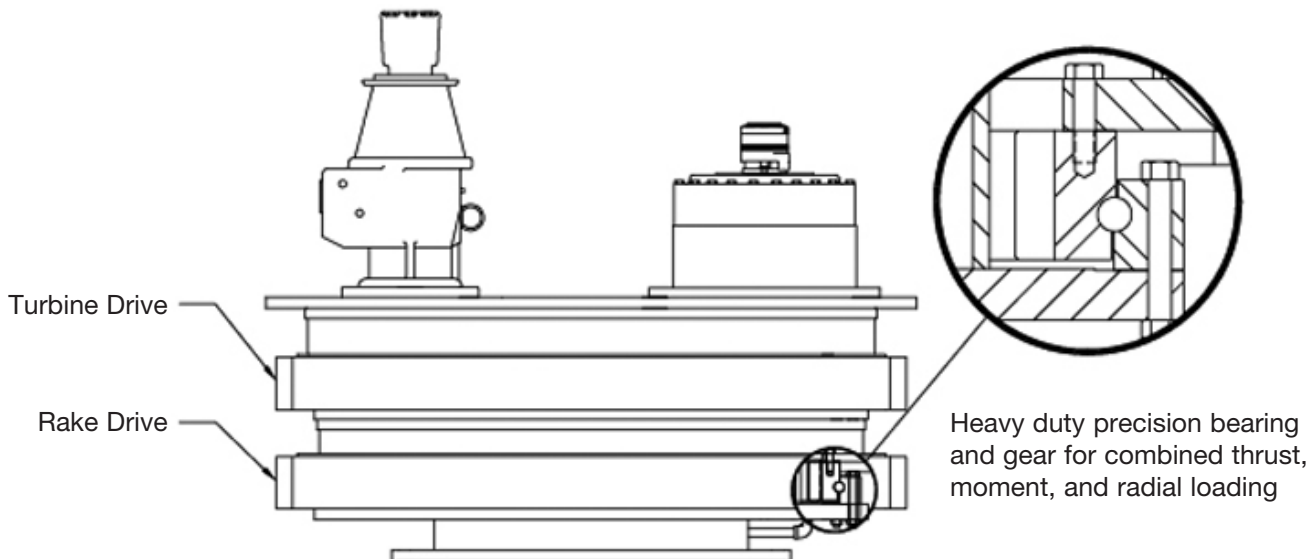

Pier-Mounted Dual Concentric Drum Output Drive Units

DD-Series Capacities



- 10-year warranty on main gear-bearing
- Rake drive has accurate torque gauge calibrated in ft-lbf, N-m or any units required
- Forged alloy steel main gear-bearing designed for over 20 years of life as calculated per AGMA 2001-C95
- Variable speed turbine drive is standard
- Alarm and cutoff switches and maximum torque-limiting via shear pin or pressure relief valve
- Permanently lubricated rake intermediate gear box, oil bath lubricated main gear housings

Rake Torque Capacity - Pier-Mounted Dual Drives							TURBINE DRIVE POWER ¹	
Model	Continuous		Maximum Overload		Yield		Allowable	Max. Speed
	ft-lb	N-m	ft-lb	N-m	ft-lb	N-m	Horsepower	rpm
D30-A*-D30	16,000	22,000	32,000	44,000	94,000	127,000	25	32
D30-B*-D30	27,000	36,500	54,000	73,000	94,000	127,000	25	32
D42-B*-D42	35,000	47,500	70,000	95,000	195,000	264,000	50	24
D42-C*-D42	51,000	69,000	102,000	138,000	195,000	264,000	50	24
D60-C*-D60	65,000	88,000	130,000	176,000	440,000	597,000	75	17
D60-D*-D60	110,000	149,000	220,000	298,000	440,000	597,000	75	17
D80-D*-D80	145,000	196,500	290,000	393,000	750,000	1,017,000	100	13
D80-E*-D80	250,000	339,000	500,000	678,000	750,000	1,017,000	100	13
D42-B*2-D42	70,000	95,000	140,000	190,000	390,000	528,000	50	24
D42-C*2-D42	102,000	138,000	204,000	276,000	390,000	528,000	50	24
D60-C*2-D60	130,000	176,000	260,000	352,000	880,000	1,194,000	75	17
D60-D*2-D60	220,000	298,000	440,000	596,000	880,000	1,194,000	75	17
D80-D*2-D80	290,000	393,000	580,000	786,000	1,500,000	2,034,000	100	13
D80-E*2-D80	500,000	678,000	1,000,000	1,356,000	1,500,000	2,034,000	100	13

¹ For higher horsepower requirements or higher speed, consult factory.

Replace the * with the primary reducer option selected.

Continuous: Torque at which main gear will have a life in excess of 20 years at normal operating speeds.

Maximum Overload: The maximum safe, short term operating torque.

Yield: The structural maximum torque based on the minimum yield strength of the main gear.

Pier-Mounted Dual Concentric Drum Output Drive Units

DD-Series Dimensions



- | Item | Description |
|------|---------------------------------|
| 1 | Machine Frame |
| 2 | Drive Drum, Rake |
| 3 | Main Gearbearing, Rake |
| 4 | Drive Drum, Turbine |
| 5 | Main Gearbearing, Turbine |
| 6 | Pinion Support Bearing, Turbine |
| 7 | Pinion, Turbine |
| 8 | Primary Speed Reducer, Turbine |
| 9 | Primary Drive, Turbine |
| 10 | Oil Drain, Turbine |
| 11 | Oil Drain, Rake |
| 12 | Primary Speed Reducer, Rake |
| 13 | Planetary Gearbox, Rake |
| 14 | Pinion, Rake |
| 15 | Pinion Support Bearing, Rake |

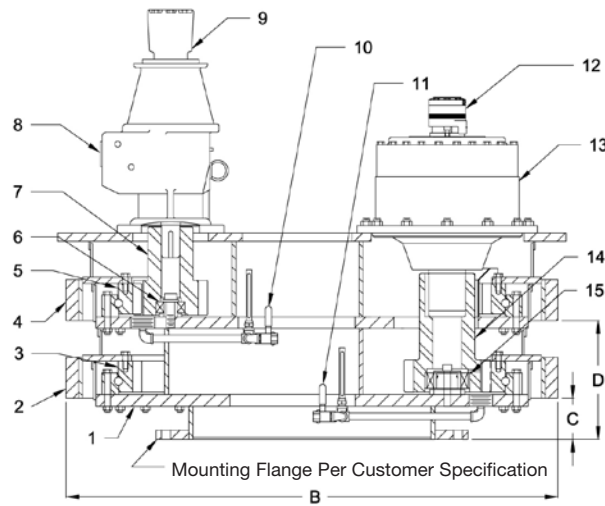
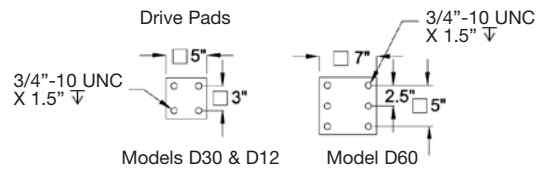
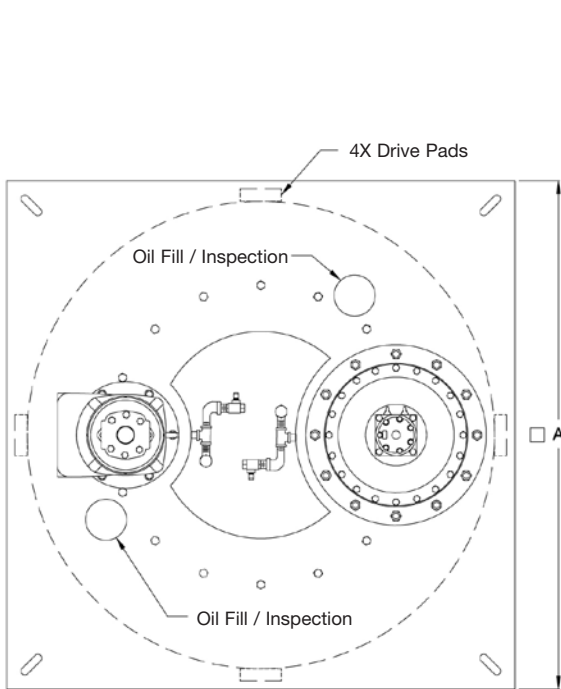

Model	A		B		C		D		Std. Mounting Flange ¹		Weight	
	in	mm	in	mm	in	mm	in	mm	in	mm	lb	kg
D30-A*-D	48	1,219	47	1,194	5	127	14.25	362	32	813	5,200	2,359
D30-B*-D	48	1,219	47	1,194	5	127	14.25	362	32	813	6,400	2,903
D42-B*-D	60	1,524	60	1,524	5	127	14.5	368	44	1,118	8,000	2,629
D42-C*-D	60	1,524	60	1,524	5	127	14.5	368	44	1,118	8,600	3,901
D60-C*-D	84	2,134	80	2,032	6	152	17.75	451	62	1,575	12,800	5,806
D60-D*-D	84	2,134	80	2,032	6	152	17.75	451	62	1,575	14,800	6,713

¹Maximum standard outside diameter of mounting flange. For larger flange sizes, contact factory. Replace the * with the primary reducer option selected.

Pier-Mounted Dual Concentric Drum Output Drive Units

Rake Primary Speed Reducer Option

W-Type



E-Type



F-Type



H-Type

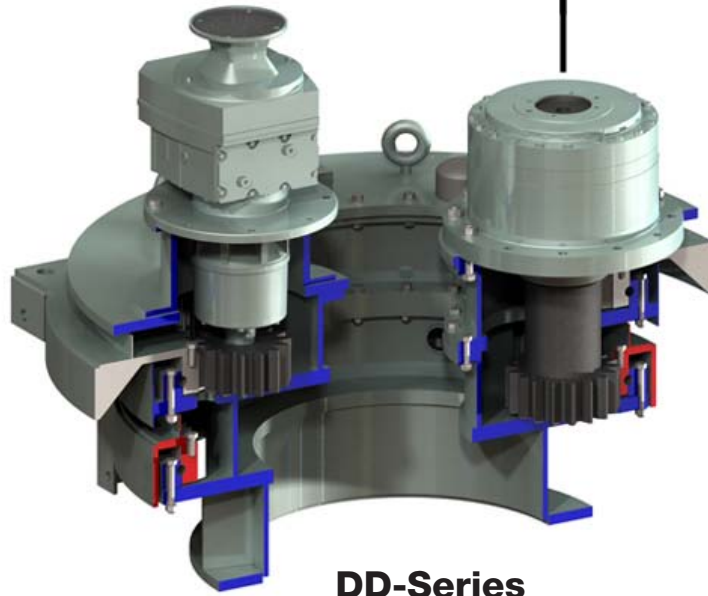
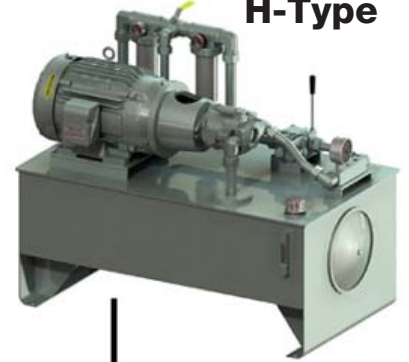

DD-Series

One of the items above will be used with one of the items below to make a complete drive unit assembly.

Pier-Mounted Dual Concentric Drum Output Drive Units

Primary Reducer Option

E-type primary speed reducer

The E-type design uses helical gears for speed reduction. It has alarm and cutoff switches and a shear pin to provide triple protection of the drive unit. This design is used where the output speed is outside the limits of the F-type primary speed reducers or when an electro-mechanical type drive unit is desired.



F-type primary speed reducer

The F-type design uses a hydraulic pump-motor combination for speed reduction. It has alarm and cutoff switches and hydraulic relief (equivalent to a shear pin in the E-type primary speed reducer) to provide triple protection of the drive unit. This design is positive torque-limiting and will operate under stalled and semi-stalled conditions. Optional reversing rotation and variable speed are available. The torque indication and protection system is equally accurate for operation in either direction.



H-type primary speed reducer

The H-type design has all the features of the F-type primary speed reducer. It uses a stand-alone industrial hydraulic power unit. This design is used on higher horsepower and multiple pinion drive applications.



W-type primary speed reducer

The W-type design uses helical gears for speed reduction. It has shear pin and shear pin activated cutoff switch to protect the drive unit. This is simplified E-type design used where a torque gauge and adjustable alarm switch are not required.



Pier-Mounted Dual Concentric Drum Output Drive Units

Turbine Variable Speed Primary Reducer Options

Electrical Type



Mechanical Type



Hydraulic Type

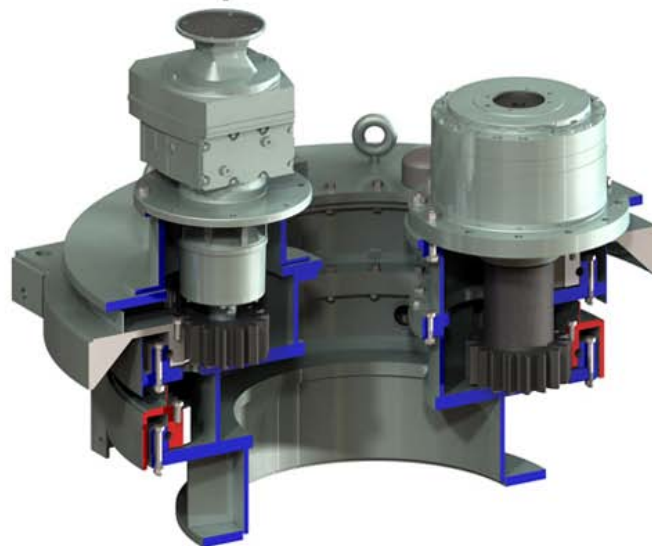

Electrical type variable speed reducer

The electrical type variable speed reducer is a variable frequency drive (VFD) that controls the output speed of the electric motor. The VFD can be mounted near the drive unit or at a remote location. VFDs provide a clean, maintenance-free, and economical way of attaining variable speed. Standard features include forward and reverse, speed indication, motor overload protection, soft-start, 4-20 mA signal, and monitoring of operating conditions. These reducers provide a 5:1 variable speed range or 10:1 when used with an inverter duty motor.

Mechanical type variable speed reducer

The mechanical variable speed reducer is a ring-cone or a disc design. The output speed varies as the pitch-line distance between two rotating components decreases or increases. The speed variation is adjusted by turning a hand-wheel on the reducer. These reducers include a standard NEMA C-frame on both the input and output connections for easy installation and removal. The reducers provide a 5:1 variable speed range.

Hydraulic type variable speed reducer

The hydraulic type variable speed reducer is a stand-alone industrial hydraulic power unit with a variable volume piston pump and hydraulic motor combination for speed reduction. This design is used when the rake primary speed reducer is an H-type design. A screw located on the pump is turned to change the stroke of the pump pistons and vary the amount of oil delivered to the hydraulic motor, thus varying the final output speed of the drive unit. These speed reducers provide a 3:1 variable speed range.

Pier-Mounted Dual Concentric Drum Output Drive Units

Ordering Information

Pier-Mounted Dual Concentric Drum Output Drive Unit Model Number						Turbine Specification Extension			
Series	Rake Gear Pitch Dia. (inches)	-	Secondary Speed Reducer	Primary Speed Reducer	Number of Pinions	-	Turbine	Turbine Gear Pitch Diameter (inches)	Maximum Turbine HP
D	30		A	E F H W	1 (omit)		D	30	25
			B					42	50
	42		B		1 (omit)			42	50
	C		2		60			75	
	60		C		1 (omit)			60	75
	D		2		80			100	
	80		D		3			80	100
	D		4						

Example: Model D30-AF-D3015

D is for a pier-mounted drive unit; 30 is the size of the final rake gear pitch diameter in inches; A is the size of the secondary speed reducer; F is the type of the primary reducer; D is for turbine drive; 30 is the size of the turbine gear pitch diameter in inches; 15 is the turbine horsepower.

Standard Features

- Alarm and cutoff switches
- O&M manual in PDF format
- 6" torque gauge indicating real torque
(not available on H-type primary reducer)

Optional Features

- 4-20 mA torque transducer
- Bi-directional operation (available for F and H-type primary reducers)
- Loss motion switch
- Variable speed, turbine
- Variable speed, rake
- Special coating
- Special electric motor
- Oil heater (available for F and H-type primary reducers and main gear housing)
- Oil temperature switch
- Oil level switch
- Explosion proof switches



**Pier-Mounted Dual Concentric Drum Output
Drive Units
Model D42-CH-D42**

Clarifier & Thickener Drives

Retrofits

Low-Speed Surface Aerators

Rotary Distributor Center Mechanisms

DBS Manufacturing, Incorporated

45 SouthWoods Parkway, Atlanta, Georgia 30354 USA

404.768.2131 phone 404.761.6360 fax

www.dbsmfg.com email: engineering@dbsmfg.com